

Product No. **8261-509-12**
 S No. **4212258**
 EAN No. **7312908261128**



Opus 200/140 Sauna

Opus 200 is an elegant cylindrical light fitting in a timeless design with a ceramic base and matt white shade. Suitable for both wall and ceiling in a sauna.

Specification

Base material	Porcelain
Lampholder	E27
Light source	Max 40W ceiling/60W wall (incl.)
Voltage	230V
Installation	Ceiling/wall
Base colour	Grey NCS S 6005-G50Y
Safety class	II
Protection class	IP44
Energy class	G
T _a	Max +125
Height	140 mm
Diameter Ø	204 mm
Glass	Matt opal
Thread	185,5 mm
Weight	2 kg
Design	Duoform

Installation

Insert the mains supply cable through the bottom inlet. Push the silicone sleeves included over the leads. Fix the light fitting to a wall or ceiling with suitable screws. Make sure the arrow and text UP at the bottom of the base points upwards for wall installation. Connect the leads to the terminals on the lamp holder. Insert a light source and then fasten the shade by turning it clockwise. Make sure the gasket between the glass and base is in place.

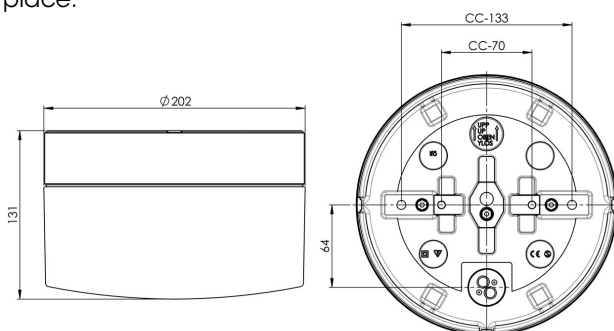

Technical information

Silicone gasket between glass and base. Four Ø 5mm holes for installation. CC measurements 133 mm or 70 mm. One bottom inlet for two mains supply cable. Terminal connection of max 2 x 1,5 mm². Bridging is possible. Bottom inlet, three knock out openings. The luminaire is designed to be installed in ambient temperatures of up to 125 °C. Also approved for steam rooms. Sauna light source, E27, 40W included.

Maintenance

Switch off the power to the fixture. Remove the shade and clean it. Do not use cleaning agents containing solvents. Change the light source if necessary. Check the gasket and change it if necessary. Replace the shade.

Spare parts

Shade: Part no 1-6183-30
 Gasket: Part no 3431
 Sauna light source: 6323-10 / 83 819 77

If the luminaire is modified the person responsible for the modification shall be considered manufacturer. Subject to errors in text. We reserve the right to change the technical specifications (without notice).