

Product No. **8352-500-16**
 S No.
 EAN No. **7312908352062**



Ohm 140/170

A family of porcelain luminaires for walls, ceilings and tables. Designed by Kauppi & Kauppi, the soft curves and restrained silhouette references to both Scandinavian design and ancient Japanese tableware.

Specification

Base material	Porcelain
Lampholder	E27
Light source	Max 40W (not incl.)
Voltage	230V
Installation	Ceiling/wall
Base colour	Black NCS S 9000-N
Safety class	II
Protection class	IP44
Energy class	-
T _a	-30 - +25
Height	167 mm
Diameter Ø	138 mm
Glass	Matt opal
Thread	123,5 mm
Weight	1,57 kg
Design	Kauppi & Kauppi

Installation

Insert the mains supply cable through the bottom inlet. Fix the light fitting to the wall or to the ceiling with suitable screws. Connect the leads via the terminal connection. Fasten the lamp holder. Insert a light source and then fasten the shade by turning it clockwise. Make sure the gasket between the glass and base is in place.

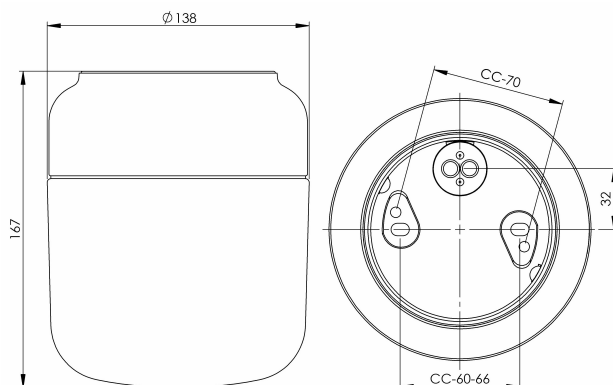

Technical information

Silicone gasket between glass and base. Two Ø 5mm holes for installation. Two holes CC measurement 70 mm, alternatively two hidden holes CC measurement 60-66 mm. One bottom inlet for two mains supply cable. Terminal connection for 2 x 2,5 mm². Bridging is possible. Bottom inlet. No knock out openings.

Maintenance

Switch off the power to the fixture. Remove the shade and clean it. Do not use cleaning agents containing solvents. Change the LED module if necessary. Check the gasket and change it if necessary. Replace the shade.

Spare parts

Shade: 1-6168-30
 Gasket: 02789

If the luminaire is modified the person responsible for the modification shall be considered manufacturer. Subject to errors in text. We reserve the right to change the technical specifications (without notice).

